

Hubbard County Highway Department

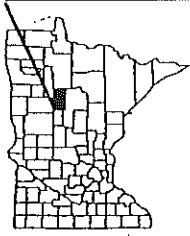

101 Crocus Hill Street
Park Rapids, MN 56470

Phone: 218-732-3302
Fax: 218-732-7640

David A. Olsonawski, P.E.
Engineer, Public Works Coordinator

Jed Nordin, Assistant Engineer
Herb McCormick, Maintenance Superintendent

TO: Driveway Entrance Applicants

FROM: County Engineer/Public Works Coordinator

RE: County Ordinance No. 5, "Regulation of Approaches and Utility Installations on Right-of-Way of County Roads".

Item No. 2 - Regulations:

- 2.1** No approach or entrance shall be constructed unless the owner of the land served by same shall have in his possession a valid permit signed by the County Highway Engineer of Hubbard County. The person constructing such entrance, if different from the landowner, shall have in his possession a copy of said permit during said construction. The issuance of this permit is to be conditioned on such items as public safety, drainage, sight distances, and esthetics in addition to considerations of convenience and necessity to the landowner.
- 2.2** A non-refundable entrance application fee as determined by the Hubbard County Board of Commissioners paid by cash, check or money order payable to the HUBBARD COUNTY TREASURER OR HUBBARD COUNTY HIGHWAY DEPARTMENT will be required by the County Engineer prior to inspection of driveway entrance. This fee will cover the cost of inspection and a culvert for drainage if necessary. If a larger than standard size entrance is requested by the applicant and approved, the costs of the additional culvert required will be paid for by the applicant prior to delivery. Culverts will be furnished by the County and remain the property of the County.
- 2.3** Installation of the culvert is the applicant's responsibility and shall substantially comply with the specifications of the County Highway Department. During the course of a general road building or rebuilding either by contract or county forces, necessary entrances will be built at County expense.
- 2.4** Please obtain a location marking stake from the Hubbard County Highway Department or Environmental Services Office upon submittal of application and install in the center of the proposed driveway location site. Upon receipt of an entrance application, the Engineer or his/her representative will inspect the site for location approval and culvert requirement at his/her earliest convenience. The Engineer or his/her representative shall be the sole judge in the above determination. Applicant will be notified of the Engineer's decision; if approved, the entrance permit will be issued. If a culvert is required it will be delivered on date specified by applicant with a 72 hour advance notice.
- 2.6** Any person not complying with this ordinance shall be guilty of a misdemeanor and subject to a fine for violation of any provision of this ordinance.

HUBBARD COUNTY HIGHWAY DEPARTMENT
APPLICATION FOR ACCESS DRIVEWAY PERMIT

Road No. _____

Print or type application. Fill out copy, sign and mail to Hubbard County Highway Department, 101 Crocus Hill Street, Park Rapids, MN 56470.

A SKETCH OF THE PROPERTY, PRESENT AND PROPOSED DRIVEWAYS AND RELATION TO COUNTY HIGHWAY MAY BE REQUIRED BY THE ENGINEER.

Name of Applicant _____ Address _____

City, State & Zip _____ Tel. _____

Name of Property Owner _____ Address _____

City, State & Zip _____ Tel. _____

Location of proposed driveway:

Road Name/No. _____ in Hubbard County _____ Miles N-S-E-W of _____
(Circle One) (Specific road, landmark, or road intersection)

Legal Description of Property _____

Purpose of Driveway _____ Residence _____ Commercial/Other (specify type) _____

Is a Building to be Constructed? _____ No _____ Yes _____ What Kind? _____

Will the Building be _____ Temporary or _____ Permanent Is the Property _____ Platted _____ Unplatted

Distance from center of highway to front of building, or front of pump island is _____ feet.

Is land _____ higher? _____ lower? or _____ level? with highway.

Number of Present Driveways to Property _____ Date Proposed Driveway Will Be Needed _____

Give Exact Location of Proposed Driveway to Property _____

Give Exact Location of Present Driveway to Property _____

I, We, the undersigned, herewith make application for permission to construct the access driveway at the above location, said driveway to be constructed to conform with the regulations of the Hubbard County Highway Department. It is further agreed that no work in connection with this application will be started until the application is approved and the permit issued. It is expressly understood that this permit is condition upon replacement or restoration of the county highway to its original or to a satisfactory condition. It is further understood that this permit is issued subject to the approval of the local city, village or borough authorities having joint supervision over said street or highway.

Date

Signature of Applicant

DO NOT WRITE BELOW THIS LINE

Inspected By: _____

Date: _____

**For
Office
Use Only**

Delivered By: _____

Date: _____

Applicant Notified By: _____

Date: _____

Pipe Size if Needed: _____

Date Paid: _____

GENERAL INFORMATION

To minimize site plan changes, it is desirable that preliminary driveway layouts for proposed driveways at commercial sites be submitted by the applicant to the County Engineer prior to making the permit application. By this means, construction and maintenance plans for the portion of the county highway under consideration may suggest alternate or improved methods or standards of construction or reconstruction to the property owner and/or lessee.

Commercial and industrial driveways should generally be wide enough for two-way operation on two-way streets. The use of design vehicle templates to check the plan layout is recommended. The driveway dimensions listed in Table I of the Regulations should generally be adequate, but variations in width of the buffer area, driveway angle, radii, and site characteristics suggest that careful attention be given to selecting the correct combination of dimensions for the specific site. Inadequate width is hazardous to vehicular traffic, and excessive width is hazardous to pedestrian traffic.

Generally, near left and near right corner driveways should be opposite each other. Where property corners on opposite sides of the street are located such that the corresponding corner driveways would not be located directly opposite each other (skewed intersections and/or varying R/W widths), the near right side property corner should be used for locating both driveways.

REQUIREMENTS

1. No work under this application is to be started until application is approved and the permit issued.
2. Where work on travelled roadway is necessary, traffic must be protected, and flags, flares, and proper barricades must be placed in accordance with the standards of the Hubbard County Highway Department.
3. No foreign material such as dirt, gravel, or bituminous material shall be left or deposited on the road during the construction of driveway or installation of drainage facilities.
4. Roadside must be cleaned up after work is completed.
5. After driveway construction is completed the applicant shall notify the County Office that the work has been completed and is ready for final inspection and approval by the Hubbard County Highway Department.
6. No changes or alterations in entrances may be made at any time without written permission from the Hubbard County Highway Department.
7. Driveway fill slopes shall be constructed 6:1 (6' horizontal to 1' vertical) where existing road slopes are 4:1 or better and shall be hand finished and seeded.

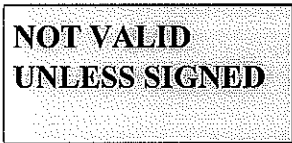

ACCESS DRIVEWAY OR ENTRANCE PERMIT

Permission is hereby granted for the consideration of the driveways as described in the above applications, said driveway to be constructed in accordance with County Ordinance No. 5 and subject to the above requirements and the following special provisions:

A fee of \$ 100.00, in the form of cash, check, or money order, payable to the Hubbard County Treasurer or Hubbard County Highway Department shall be paid at time of application.

All work to be completed by _____.
Date

In the event that the construction has not been completed within 6 months of this date, this permit becomes null and void.

County to furnish _____ X _____ culvert.

HUBBARD COUNTY HIGHWAY DEPARTMENT

County Engineer: David A. Olsonawski

Approved: _____

Date: _____

ENTRANCE CONSTRUCTION - HUBBARD COUNTY

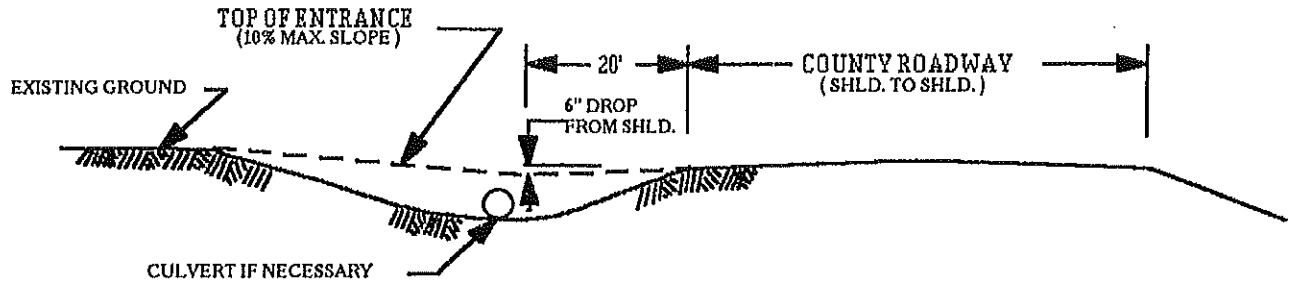

ENTRANCE ACROSS A COUNTY ROAD DITCH

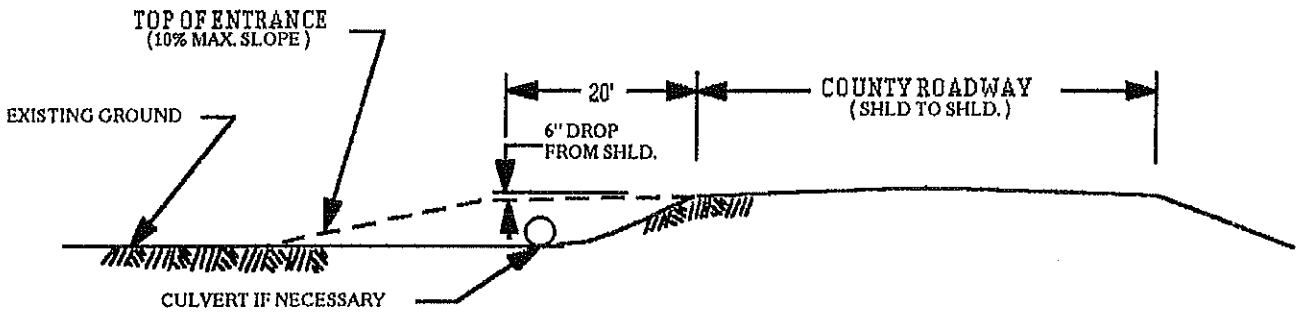

ENTRANCE WITH NO COUNTY ROAD DITCH

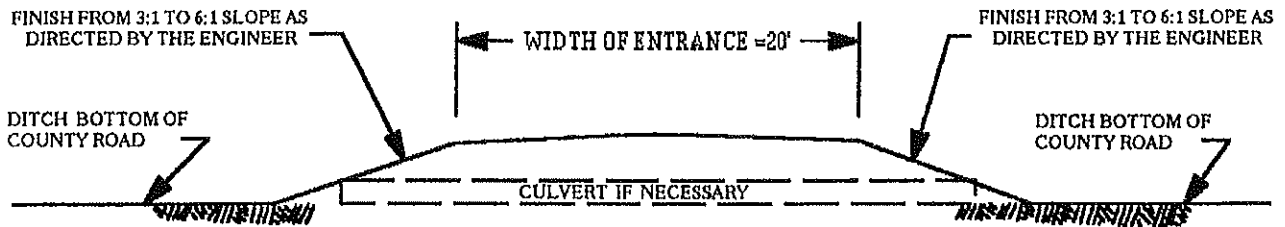

NOTE: ENTRANCE JUNCTION, WITHIN 40 FT. OF COUNTY ROADS, MUST BE AT RIGHT ANGLE.

ENTRANCE DIMENSIONS

TYPICAL DRIVEWAY SECTION

8" CONCRETE DRIVEWAY PAVEMENT ON
6" COMPACTED GRANULAR MATERIAL

